



COMPETITION/PLUS®

INSTALLATION KIT ONLY

FOUR SPEED FLOOR SHIFT

INSTALLATION INSTRUCTIONS

373 7437

U.S. PATENT NO. 3,216,274 & NO. 3,306,126

ATTENTION

Due to variations in auto manufacturing tolerances, the transmission rods supplied with this kit may require slight bending to clear obstructions, etc.

Protect the threads while bending.

**BEND RODS COLD!
DO NOT APPLY HEAT!**

WARNING!

THIS TRANSMISSION DOES NOT HAVE AN INTERLOCK TO PREVENT ENGAGEMENT OF THE REVERSE GEAR WHEN ANY OF THE FORWARD GEARS ARE ENGAGED. SEVERE DAMAGE TO THE TRANSMISSION WILL RESULT IF THIS SHOULD OCCUR. DOUBLE-CHECK THE LINKAGE BEFORE STARTING THE ENGINE OR MOVING THE CAR. INSERT NEUTRAL ALIGNMENT ROD (Pt. 1725) THROUGH LEVERS AND CHECK POSITIONS OF TRANSMISSION SHIFTING ARMS. 1-2 AND 3-4 TRANSMISSION CONTROL ARMS MUST BE AT NEUTRAL POSITIONS OF THEIR TRAVEL. REVERSE GEAR CONTROL ARM MUST BE AT FORWARD END OF ITS TRAVEL (**DIS-ENGAGED**).

CHECK THE PART NUMBERS STAMPED ON ALL PARTS RECEIVED WITH KIT WITH THE PART NUMBERS SPECIFIED

- Disconnect and remove stock linkage at transmission and shifter. Remove the escutcheon from the console (by removing four screws that fasten it). Remove the boot that is fastened to the floor tunnel.
- Remove the bolts that secure the transmission to the cross-member. Move the transmission toward the right to gain clearance from the floor. Remove the bolts that fasten the the stock shifter to the mounting plate. Be careful to avoid losing the special nut that secures the 3/8" diameter mounting bolt behind the mounting plate. Remove the stock shifter.
- Remove stick from HURST shifter. Align the levers of the shifter at their neutral positions. Insert the neutral alignment rod (Pt. 1725) through the holes in the levers. Install the shifter on the stock mounting plate using the stock mounting bolts to fasten it. Install the stick onto the shifter from above (inside car). Take care to align the serrations before tightening bolts that fasten the stick.
- Assemble rods to with their respective arms using nylon bushings and spring clips. Refer to exploded Assembly View for proper parts combinations. Assemble rod-adjusting buttons with threaded ends of rods.
- Install arm/rod assemblies to their respective transmission shafts. Fasten arms on shafts with stock hardware. Rotate each arm through its full travel to locate NEUTRAL position. NEUTRAL is the MID-POSITION of travel for 1st-2nd and 3rd-4th shafts and ALL THE WAY FORWARD fro the reverse shaft.
- Adjust the button on each rod so that the point of the button will fit the hole in the bushing in the corresponding lever. TRANSMISSION ARMS MUST REMAIN AT THEIR NEUTRAL POSITIONS WHILE BUTTONS ARE ADJUSTED TO FIT FREELY INTO BUSHING HOLES. Fasten buttons with spring clips.
- Remove neutral alignment rod. Test shifter. Stick should move freely from side-to-side at neutral (between 1-2 and 3-4 shifting paths). An increased pull toward the operator should engage the reverse lever. Install backdrive rod in hole at the lower end of the reverse lever. Fasten with spring clip.

If the stick CANNOT be moved freely between 1-2 to 3-4 or reverse path, one or more of the rod button adjustments must be corrected. Move stick forward to 3rd, then back to 4th, then into neutral. Insert neutral alignment rod. If rod CANNOT be inserted freely, the 3-4 rod button is incorrectly adjusted. Similar testing of 1-2 shift will prove alignment of 1-2 rod adjustment.

To check reverse rod button adjustment, place stick at neutral. Disconnect reverse rod adjusting button from reverse lever. Grasp rod and push all the way toward front of car. Adjust rod button for easy slip-in fit in bushing. Re-assemble and fasten with spring clip.
- Remove 3rd gear stop bolt and jam nut. Install back-up light switch bracket under the jam nut on this bolt. Adjust both stop bolts. Back both bolts out of shifter frame until only a few threads remain engaged. Push stick firmly into 3rd gear and hold stick. Screw 3rd gear stop bolt in until contact is felt. Back bolt out one turn and tighten jam nut. Pull stick firmly back into 4th gear. Screw 4th gear stop bolt in until contact is felt, then back stop bolt out one turn and tighten jam nut.
- Push the stock GM back-up light switch assembly into the hole at the lower end of the HURST back-up light switch bracket. Push switch as far as it will go into the bracket. Adjust the bracket by loosening the jam nut just enough to allow the bracket to turn. Aim the switch plunger at the REVERSE lever. This switch is self-adjusting and will position its travel depth automatically. Tighten the jam nut.

CONTENTS OF KIT

6. ROD ADJUSTING BUTTON	Pt. 119 3783 (3)	12. ROD	3-4	Pt. 213 2145
7. NYLON BUSHING	Pt. 118 1681 (6)	13. ARM	REVERSE	Pt. 105 7128
8. SPRING CLIP	Pt. 97000015 (6)	14. ROD	REVERSE	Pt. 213 3691
9. ARM	1-2	15. BACK-UP LIGHT SWITCH BRACKET		Pt. 117 6889
10. ROD	1-2	16. NEUTRAL ALIGNMENT ROD		Pt. 148 1725
11. ARM	3-4		BAGGED HARDWARE	Pt. 154 6821



PERFORMANCE GROUP®
Cleveland, Ohio
216.688.8300
www.mrgasket.com



COMPETITION/PLUS[®] INSTALLATION KIT ONLY

373 7437

FOUR SPEED FLOOR SHIFT U.S. PATENT NO. 3,216,274 & NO. 3,306,126
INSTALLATION INSTRUCTIONS

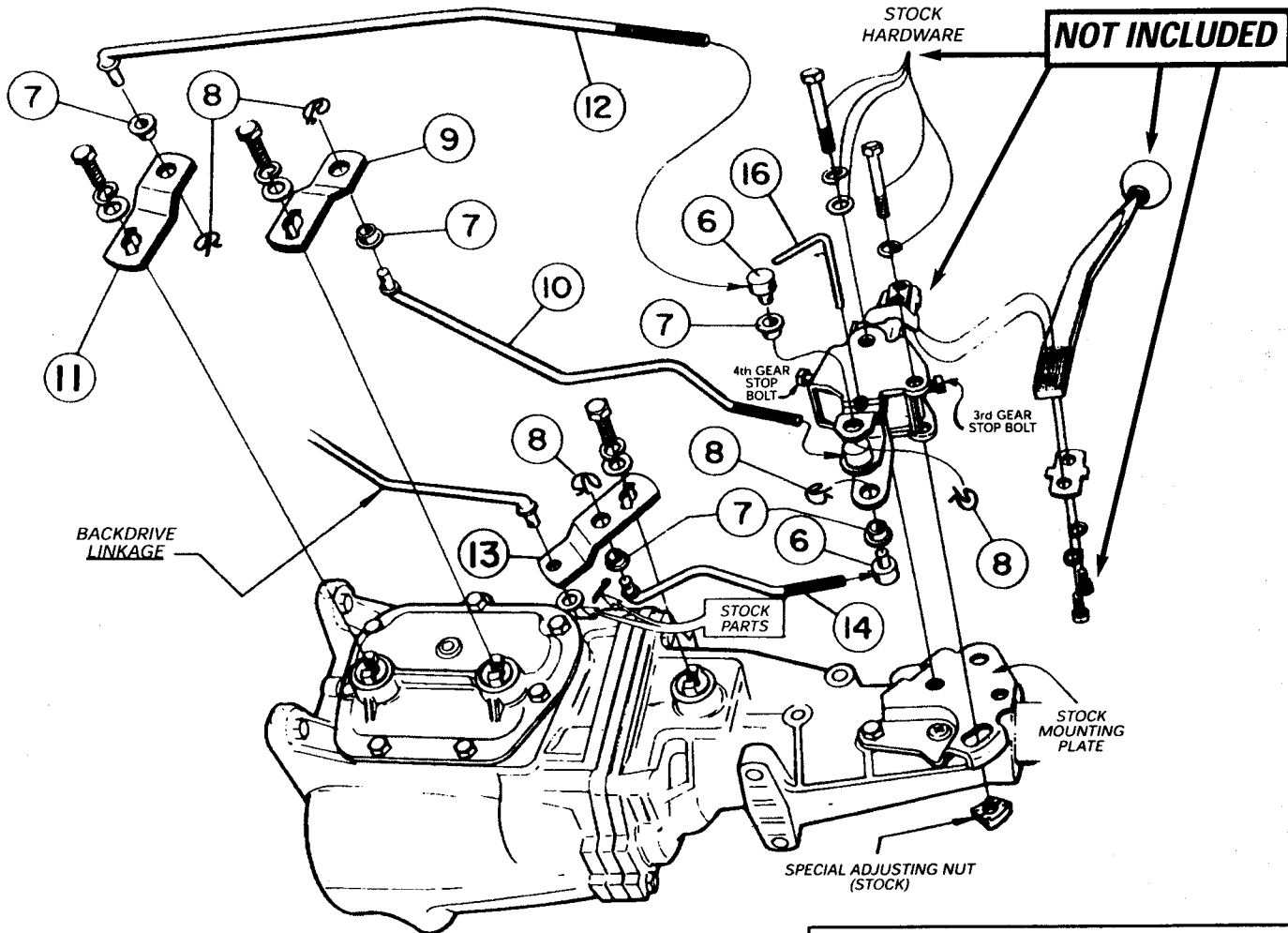

**NOT INCLUDED
IN THIS KIT**

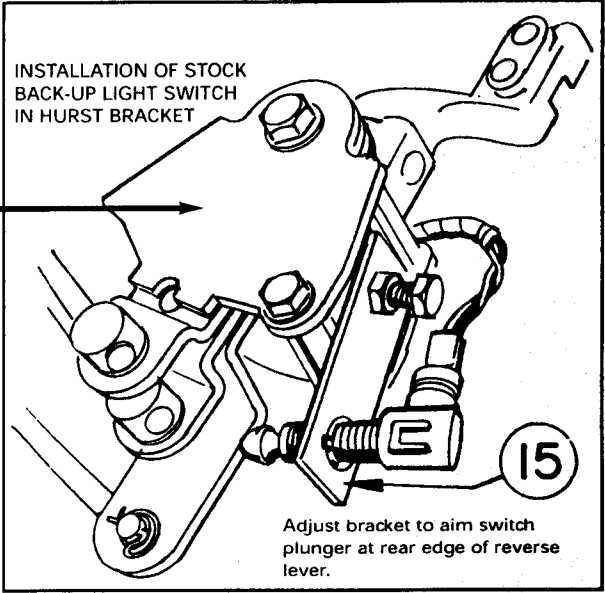

MR. GASKET CO.
PERFORMANCE GROUP[®]
Cleveland, Ohio
216.688.8300
www.mrgasket.com



INSTALLATION INSTRUCTIONS MOUNTING PLATES

If your transmission does not have a stock GM mounting plate, use the mounting plate in kit.

Shifter is installed as shown on shifter installation instruction sheet. All necessary hardware is provided.

NOTICE

Spacer plate (PT-195 4319) supplied with these mounting plates must be installed between the shifter and mounting plate.

MOUNTING PLATE PT. 195 0163 BAGGED HARDWARE PT. 154 0163

INSTALLATIONS:

373 7897
373 8605

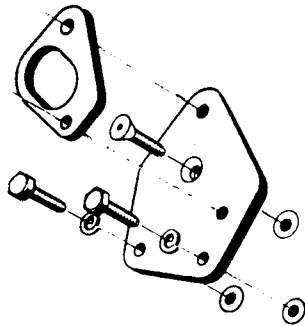

MOUNTING PLATE PT. 195 0164 BAGGED HARDWARE PT. 154 0162

INSTALLATIONS:

373 7437

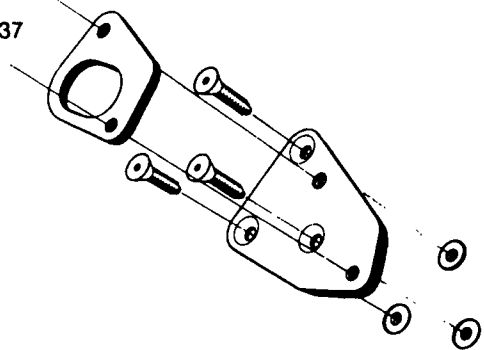

MOUNTING PLATE PT. 195 0165 BAGGED HARDWARE PT. 154 0163

**INSTALL SHIFTER
ON LOWER SET OF
MOUNTING HOLES**

INSTALLATIONS:

373 6819

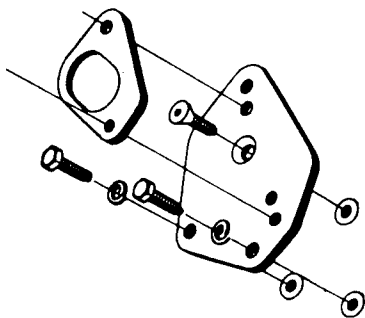

MOUNTING PLATE PT. 195 0165 BAGGED HARDWARE PT. 154 0163

**INSTALL SHIFTER
ON UPPER SET OF
MOUNTING
HOLES**

INSTALLATIONS:

373 7823
373 8608

